

2306-VS

Dual-Channel Battery/Charger Simulator with External Triggering



- External trigger inputs speed and simplify control of output channels
- Built-in test sequencing reduces GPIB bus traffic and improves test throughput
- Ultra-fast response to transient load currents
- Selectable trigger level polarity
- Variable output resistance for simulating battery response (U.S. Patent No. 6,204,647)
- Trigger outputs provided for event handshaking
- 100nA DC current sensitivity
- Sink up to 3A
- Open sense lead detection
- Built-in digital voltmeter

The Model 2306-VS combines these external trigger inputs with built-in test sequencing to create an extremely fast voltage supply and measurement instrument that minimizes the need for computer and GPIB interaction.

External Triggering Allows High Speed Control of Output Channels

When triggered, the output channels can be instructed to operate at pre-defined voltages or to initiate current, voltage, or pulse current measurements. The availability of two inputs makes it possible to program each channel to act independently or, if the test developer prefers, to act in parallel. For example, Channel #1 can be programmed to operate at user-specified voltage levels while Channel #2 is triggered to take measurements. Measurements are stored in a reading buffer and can be downloaded to a PC controller after the test routine is complete, minimizing GPIB command and data transfer delays. Trigger outputs indicate event completion, allowing users to minimize step delays between trigger-in sequences.

External triggering also allows the Model 2306-VS to exercise tight control over signal capture timing for greater measurement and load condition coordination. As a result, manufacturers can achieve greater confidence in their own compliance testing and can offer their customers more accurate component specifications.

This precision power supply has ultra-fast transient response to duplicate the output characteristics of actual batteries. In response to large load changes, voltage droops on the Model 2306-VS's battery channel are less than 100mV and transient recovery times are less than 60 μ s, even when the instrument is used with long test leads. The Model 2306-VS also employs a unique variable output resistance so that the voltage output can emulate a battery's true response (U.S. Patent No. 6,204,647). By providing stable output voltage, a device-under-test (DUT) can transition from standby power (low current) to RF transmission (high current) seamlessly without nuisance tripping.

Built-in Test Sequencing Maximizes Throughput

The Model 2306-VS's built-in test sequencing capabilities allow setting up and executing up to 20 individual voltage and measurement sequences. By minimizing the need to transfer

The dual-channel Model 2306-VS Battery/Charger Simulator with External Triggering is designed specifically for development and high speed production testing of DC battery-operated products, such as cellular handsets, cellular components like RFIC power amplifiers, and other high volume precision electrical components that require a DC voltage supply. Like Keithley's original single-channel Model 2302 Battery Simulator and dual-channel Model 2306 Battery/Charger Simulator, this precision power supply has ultra-fast transient response to provide output characteristics identical to actual batteries. However, in addition to the capabilities offered by these models, the Model 2306-VS (voltage step) provides two external trigger inputs, which allow independent control of the instrument's output channels. These trigger inputs speed and simplify control of the output channels by eliminating the time lags associated with GPIB data communications.

APPLICATIONS

Development and high speed testing of DC battery-operated products, such as:

- Cellular handsets
- Cellular components like RFIC power amplifiers
- Other high volume precision electrical components

1.888.KEITHLEY (U.S. only)

www.keithley.com

KEITHLEY

2306-VS

Ordering Information

2306-VS Dual-Channel Battery/Charger Simulator with External Triggering

Extended warranty, service, and calibration contracts are available.

Accessories Supplied

User and service manuals, CS-846 output connectors mating terminal

ACCESSORIES AVAILABLE

CABLES

7007-1	Shielded IEEE-488 Cable, 1m (3.3 ft)
7007-2	Shielded IEEE-488 Cable, 2m (6.6 ft)
SC-182	Low-Inductance Coaxial Cable (42nH/ft)

RACK MOUNT KITS

4288-1	Single Fixed Rack Mount Kit
4288-2	Dual Fixed Rack Mount Kit

OTHER

2306-VS-EW	1 Year Extended Warranty
KPC-488.2	IEEE-488.2 Interface Card for the ISA Bus
KPCI-488	IEEE-488 Interface/Controller for the PCI Bus
KUSB-488	IEEE-488.2 USB-to-GPIB Interface Adapter
TestPoint	Test Development Software

Dual-Channel Battery/Charger Simulator with External Triggering

instrument commands or data over the GPIB bus, these test sequences support faster, easier production testing by allowing users to pre-define a variety of test configurations, such as:

- Trigger up to 20 voltage setpoints on Channel #1, Channel #2, or both
- Trigger up to 20 measurement readings on Channel #1, Channel #2, or both
- Trigger voltage setpoints on Channel #1 while triggering Channel #2 measurement readings

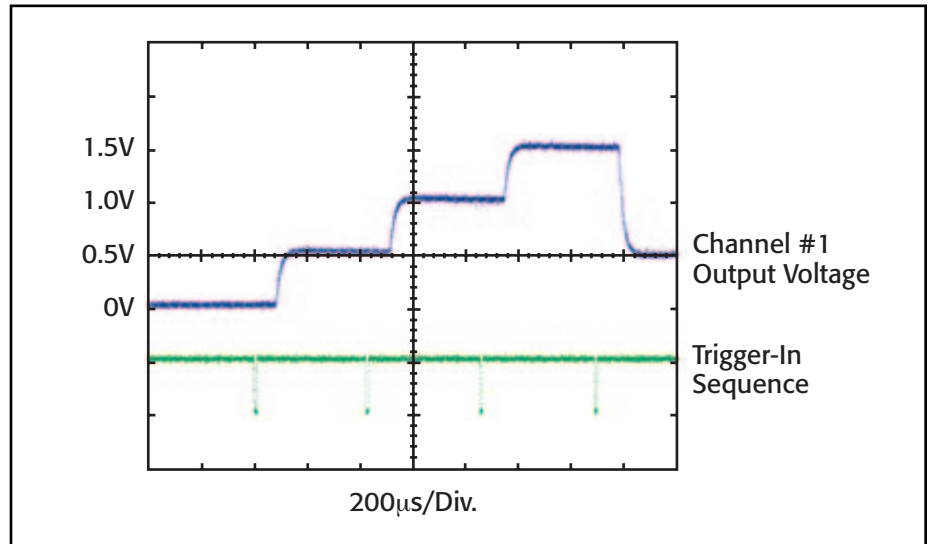

Figure 1. This graph illustrates Channel #1 output voltage response times based on a four-point voltage step sequence (0.5V/1.0V/1.5V/0.5V). The Model 2306-VS can complete this sequence within 1.5ms.

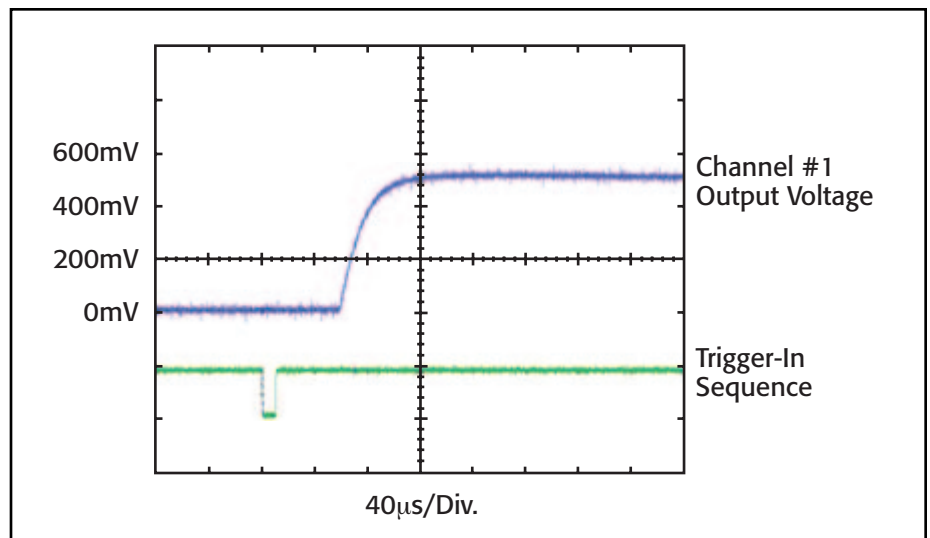

Figure 2. This magnified view of the first 500mV voltage step from the signal shown in Figure 1 illustrates how the Channel #1 output reaches the voltage setpoint within 160µs of the trigger-in pulse.

1.888.KEITHLEY (U.S. only)

www.keithley.com

KEITHLEY

A GREATER MEASURE OF CONFIDENCE

Fast transient response power supply

SPECIALIZED POWER SUPPLIES

2306-VS

Dual-Channel Battery/Charger Simulator with External Triggering

Measure Load Currents for Power Consumption Verification or Analysis

The Model 2306-VS is based on Keithley's expertise in low current measurement technologies, so it is well-suited for making accurate measurements of load currents. With 100nA resolution and 0.2% basic accuracy, it provides the precision needed to monitor the low sleep mode currents of today's battery-operated products.

The Model 2306-VS can monitor DUT power consumption by measuring both DC currents and pulse load currents. The instrument's battery-simulator channel can be programmed to operate like a discharged rechargeable battery, sinking up to 3A from the charger-simulator channel.

Maximize Test Throughput with Accurate Battery Simulation

The Model 2306-VS's battery-output channel is designed to simulate the output response of a battery. This capability, combined with its fast transient response, makes it possible to power the device during testing in exactly the same way as a battery will power the device during actual use. The output resistance of the battery channel can be programmed (with 10m Ω resolution) over the range from 0 Ω to 1 Ω so that the output resistance can be set to the same level as the output resistance of the battery that powers the device.

Portable wireless devices make great demands on their battery power sources. The battery must source load currents that can jump virtually instantaneously from a standby current level (100–300mA) to a full power RF transmission current level (1–3A). In other words, the load current on the battery can increase rapidly by a factor of 700–1000%. As a result, the battery voltage drops by an amount equal to the value of the current change multiplied by the battery's internal resistance. The Model 2306-VS enables test systems to duplicate this voltage drop by programming their output resistance to be equivalent to that of the battery that will power the device. This allows wireless device manufacturers to test their products under the same power conditions that they will encounter in actual use.

The Model 2306-VS also eliminates the large stabilizing capacitors needed at the DUT to compensate for the large voltage droop that occurs when testing with conventional power supplies. By varying the output resistance, which can be done while the output is turned on, test engineers can simulate the operation of different battery types as well as batteries nearing the end of their useful lives. The Model 2306-VS ensures maximum production throughput when testing portable devices by minimizing false failures, minimizing the number of test setups by performing multiple tests with the same power supply, and minimizing test fixture complexity by eliminating the need for voltage-stabilizing capacitors.

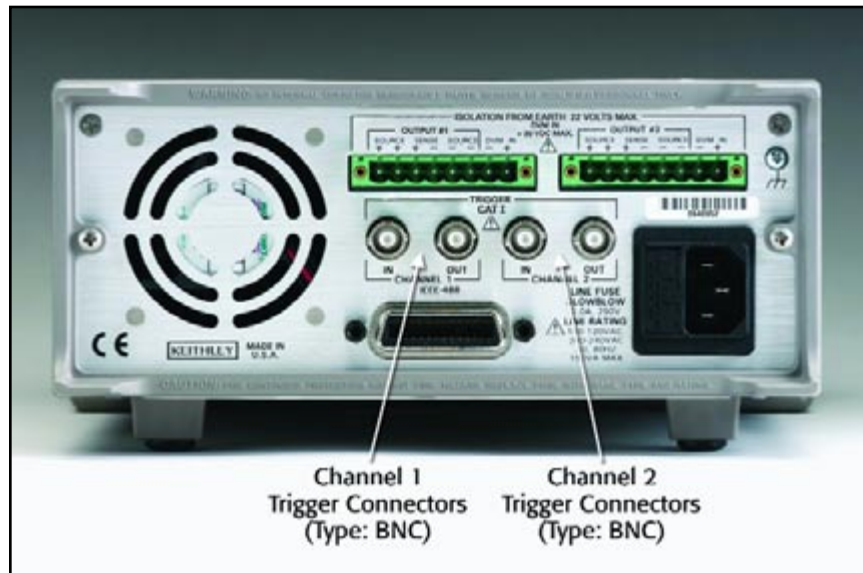

Open Sense Lead Detection

The Model 2306-VS has an automatic open-sense lead detection capability, which indicates if there is a broken remote sense lead or an open connection from a remote sense lead to the test fixture. To ensure that the output voltage does not change from the programmed level, which could cause production devices to be improperly calibrated, the user can set high and low limits around the desired voltage level.

Independent Digital Voltmeter Inputs

Many programmable power supplies offer output readback capabilities, but the Model 2306-VS also offers two digital voltmeter (DVM) inputs. These inputs can be used to measure signals from –5V to +30V DC anywhere in the test system with the same rated accuracy as the voltage readback. For many applications, this built-in DVM eliminates the expense and space otherwise required to add a separate voltage measurement instrument to the system.

1.888.KEITHLEY (U.S. only)

www.keithley.com

KEITHLEY

A GREATER MEASURE OF CONFIDENCE

2306-VS

Dual-Channel Battery/Charger Simulator with External Triggering

OUTPUT #1 (BATTERY)

DC VOLTAGE OUTPUT (2 YEARS, 23°C ± 5°C)

OUTPUT VOLTAGE: 0 to +15VDC.
 OUTPUT ACCURACY: ±(0.05% + 3mV).
 PROGRAMMING RESOLUTION: 1mV
 READBACK ACCURACY¹: ±(0.05% + 3mV).
 READBACK RESOLUTION: 1mV
 LOAD REGULATION: ±(0.01% + 2mV).
 LINE REGULATION: ±0.5mV
 STABILITY²: ±(0.01% + 0.5mV).
 MEASUREMENT TIME CHOICES: 0.01 to 10 PLC⁷, in 0.01PLC steps.
 AVERAGE READINGS: 1 to 10.
 READING TIME^{1,8,9}: 31ms, typical.

TRANSIENT RESPONSE:

	High Bandwidth	Low Bandwidth
Transient Recovery Time ¹³	<40 μs ³ or <60 μs ⁴	<80 μs ³ or <100 μs ⁴
Transient Voltage Drop	<75 mV ³ or <100 mV ⁴	<250 mV ³ or <40 0mV ⁴

REMOTE SENSE: 1V max. drop in each lead. Add 2mV to the voltage load regulation specification for each 1V change in the negative output lead due to load current change. Remote sense required. Integrity of connection continually monitored. If compromised, output will turn off automatically once settable window (±0 to ±8 volts) around normal voltage exceeded.

VARIABLE OUTPUT IMPEDANCE

RANGE: 0 to 1.00Ω in 0.01Ω steps. Value can be changed with output on if trigger external disabled on channel.

DC CURRENT (2 Years, 23°C ± 5°C)

CONTINUOUS AVERAGE OUTPUT CURRENT:

Channel #2 (Charger) OFF: $I = 50W / (V_{set} \text{ channel 1} + 6V)$; 5A max.
 Channel #2 (Charger) ON: $I = (50W - \text{Power consumed by channel \#2}) / (V_{set} \text{ channel 1} + 6V)$; 5A max.
 The power consumed by channel #2 is calculated as:
 Channel #2 sourcing current: $\text{Power consumed} = (V_{set} \text{ channel 2} + 6V) \times (\text{current supplied})$.
 Channel #2 sinking current: $\text{Power consumed} = 5 \times (\text{sink current})$.

Peak currents can be a maximum of 5A provided the average current is within the above limits.

CONTINUOUS AVERAGE SINK CURRENT:

Channel #2 (Charger) OFF:
 0–5V: 3A max.
 5–15V: Derate 0.2A per volt above 5V. Compliance setting controls sinking.

Channel #2 (Charger) ON:
 Available current = $(50W - \text{Power consumed by channel \#2}) / 5$; 3A max. (0–5V).
 Derate 0.2A per volt above 5V

SOURCE COMPLIANCE ACCURACY: ±(0.16% + 5mA)⁵.

PROGRAMMED SOURCE COMPLIANCE RESOLUTION: 1.25mA.

READBACK ACCURACY¹: 5A Range: ±(0.2% + 200μA). 5mA Range: ±(0.2% + 1μA).

READBACK RESOLUTION: 5A Range: 100μA. 5mA Range: 0.1μA.

LOAD REGULATION: ±(0.01% + 1mA).

LINE REGULATION: ±0.5mA.

STABILITY⁴: ±(0.01% + 50μA).

MEASUREMENT TIME CHOICES: 0.01 to 10 PLC⁷, in 0.01PLC steps.

AVERAGE READINGS: 1 to 10.

READING TIME^{1,8,9}: 31ms, typical.

PULSE CURRENT MEASUREMENT OPERATION

TRIGGER LEVEL: 5A Range: 5mA to 5A, in 5mA steps.
 1A Range: 1mA to 1A, in 1mA steps.
 100mA Range: 0.1mA to 100mA, in 100μA steps.

TRIGGER DELAY: 0 to 100ms, in 10μs steps.

INTERNAL TRIGGER DELAY: 15μs.

HIGH/LOW/AVERAGE MODE:

Measurement Aperture Settings: 33.3μs to 833ms, in 33.3μs steps.
 Average Readings: 1 to 100.

PULSE CURRENT MEASUREMENT ACCURACY¹¹ (2 Years, 23°C ± 5°C):

Aperture	Accuracy ±(% reading + offset + rms noise ¹⁰)
<100 μs	0.2% + 900 μA + 2 mA
100 μs – 200 μs	0.2% + 900 μA + 1.5 mA
200 μs – 500 μs	0.2% + 900 μA + 1 mA
500 μs – <1 PLC	0.2% + 600 μA + 0.8 mA
1 PLC ¹²	0.2% + 400 μA + 0 mA
>1 PLC	0.2% + 400 μA + 100 μA

BURST MODE CURRENT MEASUREMENT

MEASUREMENT APERTURE: 33.3μs to 833ms, in 33.3μs steps.

CONVERSION RATE: 3650/second at 33.3μs meas. aper., typical.

INTERNAL TRIGGER DELAY: 15μs with 33μs.

NUMBER OF SAMPLES: 1 to 5000.

TRANSFER SAMPLES ACROSS IEEE BUS IN BINARY MODE: 4800 bytes/s, typical.

LONG INTEGRATION MODE CURRENT MEASUREMENT

MEASUREMENT TIME⁶: 850ms (840ms) to 60 seconds in 1ms steps.

DIGITAL VOLTMETER INPUT (2 Years, 23°C ± 5°C)

INPUT VOLTAGE RANGE: –5 to +30VDC.

INPUT IMPEDANCE: 2MΩ typical.

MAXIMUM VOLTAGE (either input terminal) WITH RESPECT TO OUTPUT LOW: –5V, +30V

READING ACCURACY¹: ±(0.05% + 3mV).

READING RESOLUTION: 1mV

CONNECTOR: HI and LO input pair part of Output #1's terminal block.

MEASUREMENT TIME CHOICES: 0.01 to 10 PLC⁷, in 0.01PLC steps.

AVERAGE READINGS: 1 to 10.

READING TIME^{1,8,9}: 31ms, typical.

VOLTAGE SETTling TIMES

VOLTAGE STEP SETTling TIMES (typical)

Increasing Voltage	10–90% Rise Time	Settling Time
Voltage step ≤ 7 V	50 μs	300 μs
Voltage step > 7 V	50 μs to 1.2 ms	300 μs to 1.8 ms
Decreasing Voltage	10–90% Fall Time	Settling Time
0 V < Voltage step < 15 V	50 μs to 250 μs	300 μs

NOTE: Times are under no load condition and settling times defined at ±2% of step size.

Model 2306-VS Specifications

SPECIALIZED POWER SUPPLIES

1.888.KEITHLEY (U.S. only)

www.keithley.com

KEITHLEY

A GREATER MEASURE OF CONFIDENCE

2306-VS

Dual-Channel Battery/Charger Simulator with External Triggering

Model 2306-VS Specifications

OUTPUT #2 (CHARGER)

DC VOLTAGE OUTPUT (2 YEARS, 23°C ± 5°C)

OUTPUT VOLTAGE: 0 to +15VDC.
 OUTPUT ACCURACY: ±(0.05% + 10mV).
 PROGRAMMING RESOLUTION: 10mV
 READBACK ACCURACY¹: ±(0.05% + 3mV).
 READBACK RESOLUTION: 1mV
 OUTPUT VOLTAGE SETTLE TIME: 5ms to within stated accuracy.
 LOAD REGULATION: ±(0.01% + 2mV).
 LINE REGULATION: ±0.5mV
 STABILITY²: ±0.01% + 0.5mV).
 MEASUREMENT TIME CHOICES: 0.01 to 10 PLC⁷, in 0.01PLC steps.
 AVERAGE READINGS: 1 to 10.
 READING TIME^{1, 8, 9}: 31ms, typical.

TRANSIENT RESPONSE:	High Bandwidth	Low Bandwidth
Transient Recovery Time ¹³	<50 μs ³ or <80 μs ⁴	<60 μs ³ or <100 μs ⁴
Transient Voltage Drop	<120 mV ³ or <150 mV ⁴	<160 mV ³ or <200 mV ⁴

REMOTE SENSE: 1V max. drop in each lead. Add 2mV to the voltage load regulation specification for each 1V change in the negative output lead due to load current change. Remote sense required. Integrity of connection continually monitored. If compromised, output will turn off automatically once settable window (±0 to ±8 volts) around normal voltage exceeded.

DC CURRENT (2 Years, 23°C ± 5°C)

CONTINUOUS AVERAGE OUTPUT CURRENT:

Channel #1 (Battery) OFF: $I = 50W / (V_{set} \text{ channel 2} + 6V)$; 5A max.
 Channel #1 (Battery) ON: $I = (50W - \text{Power consumed by channel \#1}) / (V_{set} \text{ channel 2} + 6V)$; 5A max.
 The power consumed by channel #1 is calculated as:
 Channel #1 sourcing current: Power consumed = $(V_{set} \text{ channel 1} + 6V) \times (\text{current supplied})$
 Channel #1 sinking current: Power consumed = $5 \times (\text{sink current})$

Peak currents can be a maximum of 5A provided the average current is within the above limits.

CONTINUOUS AVERAGE SINK CURRENT:

Channel #1 (Battery) OFF:
 0–5V: 3A max.
 5–15V: Derate 0.2A per volt above 5V Compliance setting controls sinking.

Channel #1 (Battery) ON:
 Available current = $(50W - \text{Power consumed by channel \#1}) / 5$; 3A max. (0–5V).
 Derate 0.2A per volt above 5V

SOURCE COMPLIANCE ACCURACY: ±(0.16% + 5mA)⁵.

PROGRAMMED SOURCE COMPLIANCE RESOLUTION: 1.25mA.

READBACK ACCURACY¹: 5A Range: ±(0.2% + 200μA). 5mA Range: ±(0.2% + 1μA).

READBACK RESOLUTION: 5A Range: 100μA. 5mA Range: 0.1μA.

LOAD REGULATION: ±(0.01% + 1mA).

LINE REGULATION: ±0.5mA.

STABILITY⁴: ±(0.01% + 50μA).

MEASUREMENT TIME CHOICES: 0.01 to 10 PLC⁷, in 0.01PLC steps.

AVERAGE READINGS: 1 to 10.

READING TIME^{1, 8, 9}: 31ms, typical.

PULSE CURRENT MEASUREMENT OPERATION

TRIGGER LEVEL: 5mA to 5A, in 5mA steps.

TRIGGER DELAY: 0 to 100ms, in 10μs steps.

INTERNAL TRIGGER DELAY: 15μs.

HIGH/LOW/AVERAGE MODE:

Measurement Aperture Settings: 33.3μs to 833ms, in 33.3μs steps.
 AVERAGE READINGS: 1 to 100.

PULSE CURRENT MEASUREMENT ACCURACY¹¹ (2 Years, 23°C ± 5°C):

Aperture	Accuracy ±(% reading + offset + rms noise ¹⁰)
<100 μs	0.2% + 900 μA + 2 mA
100 μs – 200 μs	0.2% + 900 μA + 1.5 mA
200 μs – 500 μs	0.2% + 900 μA + 1 mA
500 μs – <1 PLC	0.2% + 600 μA + 0.8 mA
1 PLC ¹²	0.2% + 400 μA + 0 mA
>1 PLC	0.2% + 400 μA + 100 μA

BURST MODE CURRENT MEASUREMENT

MEASUREMENT APERTURE: 33.3μs to 833ms, in 33μs steps.

CONVERSION RATE: 2040/second at 33.3μs meas. aper., typical.

INTERNAL TRIGGER DELAY: 15μs with 33μs.

NUMBER OF SAMPLES: 1 to 5000.

TRANSFER SAMPLES ACROSS IEEE BUS IN BINARY MODE: 4800 bytes/s, typical.

LONG INTEGRATION MODE CURRENT MEASUREMENT

MEASUREMENT TIME⁶: 850ms (840ms) to 60 seconds in 1ms steps.

DIGITAL VOLTMETER INPUT (2 Years, 23°C ± 5°C)

INPUT VOLTAGE RANGE: –5 to +30VDC.

INPUT IMPEDANCE: 2MΩ typical.

MAXIMUM VOLTAGE (either input terminal) WITH RESPECT TO OUTPUT LOW: –5V, +30V

READING ACCURACY¹: ±(0.05% + 3mV).

READING RESOLUTION: 1mV

CONNECTOR: HI and LO input pair part of Output #2's terminal block.

MEASUREMENT TIME CHOICES: 0.01 to 10 PLC⁷, in 0.01PLC steps.

AVERAGE READINGS: 1 to 10.

READING TIME^{1, 8, 9}: 31ms, typical.

VOLTAGE SETTLE TIMES

Increasing Voltage	10–90% Rise Time	Settling Time
Voltage step ≤ 7 V	10 μs	100 μs
Voltage step > 7 V	10 μs to 1.2 ms	100 μs to 1.8 ms
Decreasing Voltage	10–90% Fall Time	Settling Time
0 V < Voltage step < 15 V	50 μs to 40 μs	50 μs to 200 μs

NOTE: Times are under no load condition and settling times defined at ±2% of step size.

SPECIALIZED POWER SUPPLIES

1.888.KEITHLEY (U.S. only)

www.keithley.com

KEITHLEY

A GREATER MEASURE OF CONFIDENCE

VOLTAGE STEPPING ONLY

TEST CONDITIONS:

1. Trigger external is enabled on both channels.
2. Only a single channel is externally triggered during the sequence while remaining channel stays idle.
3. Times based on 0 programmable user delay.

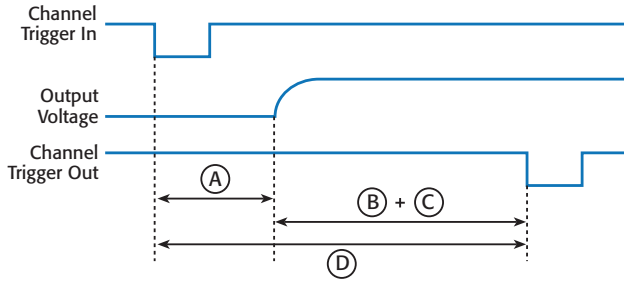

Output #1 (Battery)	Output #2 (Charger)
A = 70 μ s typical	A = 55 μ s typical
B = 330 μ s typical	B = 545 μ s typical
C = Programmable user delay (0–5 seconds)	C = Programmable user delay (0–5 seconds)
D = 400 μ s typical with C as 0	D = 600 μ s typical with C as 0

AUTO MEASUREMENT ONLY

TEST CONDITIONS:

1. Trigger external is enabled on both channels.
2. Only a single channel is externally triggered during the sequence while remaining channel stays idle.
3. Times based on 0 programmable user delay.
4. Measurement time = 167 μ s (0.01 PLC).
5. Steps points = 4.

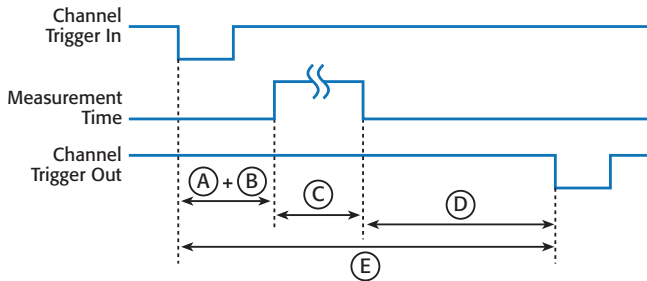

Output #1 (Battery)	Output #2 (Charger)
A = 43 μ s typical	A = 43 μ s typical
B = Programmable user delay (0–5 seconds)	B = Programmable user delay (0–5 seconds)
C = Measurement time	C = Measurement time
D = 410 μ s typical (steps 1, 2, and 3)	D = 650 μ s typical (steps 1, 2, and 3)
E = 620 μ s typical for steps 1, 2, and 3 with B as 0	E = 860 μ s typical for steps 1, 2, and 3 with B as 0
8ms typical for step 4 with B as 0	8ms typical for step 4 with B as 0

VOLTAGE STEPPING WITH AUTO MEASUREMENT

TEST CONDITIONS:

1. Trigger external is enabled on both channels.
2. Only a single channel is externally triggered during the sequence while remaining channel stays idle.
3. Times based on 0 programmable user delay.
4. Measurement time = 167 μ s (0.01 PLC).
5. Steps points = 4.

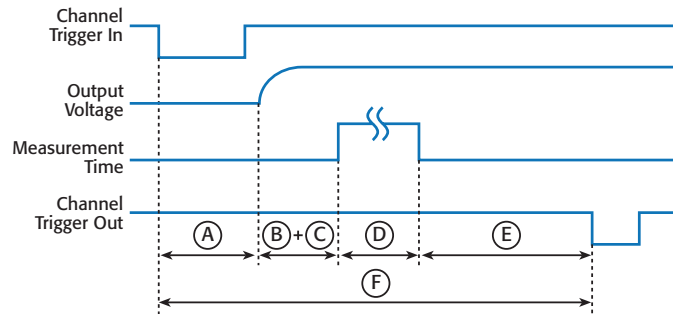

Output #1 (Battery)	Output #2 (Charger)
A = 70 μ s typical	A = 55 μ s typical within
B = 43 μ s typical	B = 43 μ s typical within
C = Programmable user delay (0–5 seconds)	C = Programmable user delay (0–5 seconds)
D = Measurement time	D = Measurement time
E = 475 μ s typical (steps 1, 2, and 3)	E = 955 μ s typical (steps 1, 2, and 3)
F = 755 μ s typical steps 1, 2 and 3 with C as 0	F = 1.22 ms typical steps 1, 2 and 3 with C as 0
8 ms typical step 4 with C as 0	8 ms typical step 4 with C as 0

VOLTAGE STEPPING BOTH CHANNELS WITH CHANNEL 1

TEST CONDITIONS:

1. Only a single channel is externally triggered during the sequence while remaining channel stays idle.
2. Times based on 0 programmable user delay.

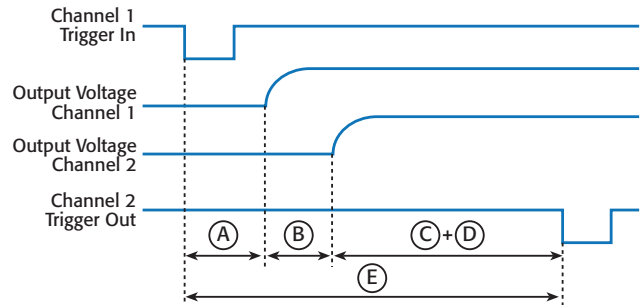

Output #1 (Battery)/Output #2 (Charger)
A = 70 μ s typical
B = 55 μ s typical
C = 775 μ s typical
D = Programmable user delay (0–5 seconds)
E = 900 μ s typical with D as 0

2306-VS

Dual-Channel Battery/Charger Simulator with External Triggering

VOLTAGE STEPPING BOTH CHANNELS WITH CHANNEL 2

TEST CONDITIONS:

1. Only a single channel is externally triggered during the sequence while remaining channel stays idle.
2. Times based on 0 programmable user delay.

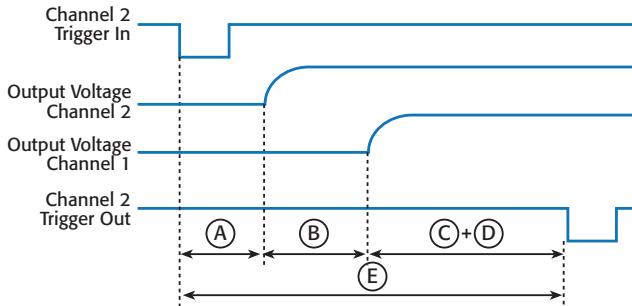

Output #1 (Battery)/Output #2 (Charger)

- A = 55 μ s typical
- B = 70 μ s typical
- C = 775 μ s typical
- D = Programmable user delay (0–5 seconds)
- E = 900 μ s typical with D as 0

AUTO MEASUREMENT BOTH CHANNELS WITH CHANNEL 1

TEST CONDITIONS:

1. Only a single channel is externally triggered during the sequence while remaining channel stays idle.
2. Times based on 0 programmable user delay.
3. Measurement time = 167 μ s (0.01 PLC).
4. Steps points = 4.

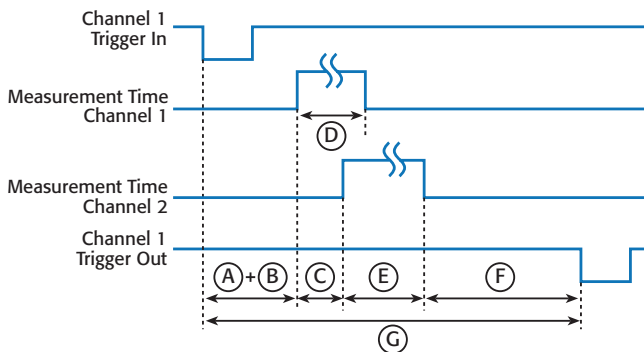

Output #1 (Battery)/Output #2 (Charger)

- A = 43 μ s typical
- B = Programmable user delay (0–5 seconds)
- C = 18 μ s typical
- D = Measurement time channel 1
- E = Measurement time channel 2
- F = 872 μ s typical with steps 1, 2, and 3
- G = 1.1 ms typical for steps 1, 2, and 3 with B as 0
16.0 ms typical step 4 with B as 0

AUTO MEASUREMENT BOTH CHANNELS WITH CHANNEL 2

TEST CONDITIONS:

1. Only a single channel is externally triggered during the sequence while remaining channel stays idle.
2. Times based on 0 programmable user delay.
3. Measurement time = 167 μ s (0.01 PLC).
4. Steps points = 4.

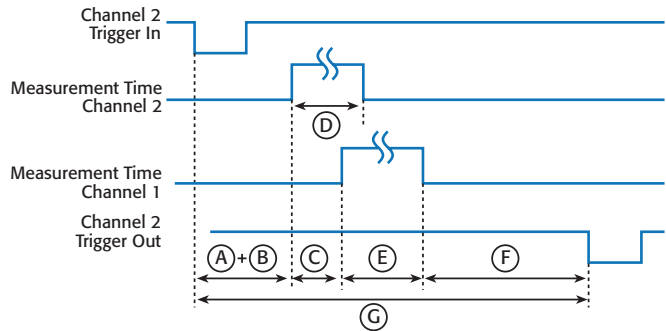

Output #1 (Battery)/Output #2 (Charger)

- A = 43 μ s typical
- B = Programmable user delay (0–5 seconds)
- C = 18 μ s typical
- D = Measurement time channel 2
- E = Measurement time channel 1
- F = 872 μ s typical with steps 1, 2, and 3
- G = 1.1 ms typical for steps 1, 2, and 3 with B as 0
16.0 ms typical step 4 with B as 0

VOLTAGE STEPPING WITH SYNC MEASUREMENT

TEST CONDITIONS:

1. Trigger external is enabled on both channels.
2. Only a single channel is externally triggered during the sequence while remaining channel stays idle.
3. Times based on 0 programmable user delay.

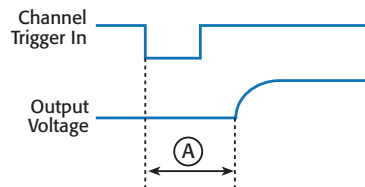

Output #1 (Battery)	Output #2 (Charger)
----------------------------	----------------------------

- | | |
|--|--|
| Channel 1 trigger in = output voltage start changing | Channel 2 trigger in = output voltage start changing |
| A = 70 μ s typical | A = 55 μ s typical within 4 ms typical to start search for desired pulse edge. Time for trigger out dependent on search time for selecting edge, integration time, and storing reading in buffer |

1.888.KEITHLEY (U.S. only)

www.keithley.com



2306-VS

Dual-Channel Battery/Charger Simulator with External Triggering

GENERAL

ISOLATION (LOW-EARTH): 22VDC max. Do not exceed 60VDC between any two terminals of either connector.

PROGRAMMING: IEEE-488.2 (SCPI).

USER-DEFINABLE POWER-UP STATES: 3.

REAR PANEL CONNECTORS: Two trigger in and two trigger out (BNC) connectors. Two 8-position quick disconnect terminal block for output (4), sense (2), and DVM (2).

TRIGGER IN/OUT CONNECTORS: IN High 3–5V IN Low $\leq 0.8V$ OUT High $> 4V$ OUT Low $< 0.8V$.

TEMPERATURE COEFFICIENT (outside 23°C $\pm 5^\circ\text{C}$): Derate accuracy specification by $(0.1 \times \text{specification})/^\circ\text{C}$.

OPERATING TEMPERATURE: 0° to 50°C (derate to 70%). 0° to 35°C (gull power).

STORAGE TEMPERATURE: –20° to 70°C.

HUMIDITY: $< 80\%$ @ 35°C non-condensing.

DISPLAY TYPE: 2-line \times 16 character VFD.

DIMENSIONS: 89mm high \times 213mm wide \times 411mm deep (3½ in \times 8½ in \times 16½ in).

NET WEIGHT: 3.9kg (8.6 lbs.).

SHIPPING WEIGHT: 6.4kg (14 lbs.).

INPUT POWER: 100–120VAC/220–240VAC, 50 or 60Hz (auto detected at power-up).

POWER CONSUMPTION: 165VA max.

WARRANTY: Two years parts and labor on materials and workmanship.

EMC: Conforms with European Union Directive directive 89/336/EEC, EN 61326.

SAFETY: Conforms with European Union Directive 73/23/EEC, EN 61010-1.

VIBRATION: MIL-PRF-28800F Type III, Class 3.

ACCESSORIES SUPPLIED: User and service manual, output connectors mating terminal (part no. CS-846).

NOTES

1. PLC = 1.00.
2. Following 15 minute warm-up, the change in output over 8 hours under ambient temperature, constant load, and line operating conditions.
3. Remote sense, at output terminals, 0.5A to 5A typical.
4. Remote sense, with 4.5m (15 ft) of 16 gauge (1.31mm²) wire and 1Ω resistance in each lead to simulate typical test environment, 1.5A load change (0.15A to 1.65A).
5. Minimum current in constant current mode is 6mA.
6. 60Hz (50Hz).
7. PLC = Power Line Cycle. 1PLC = 16.7ms for 60Hz operation, 20ms for 50Hz operation.
8. Display off.
9. Speed includes measurement and binary data transfer out of GPIB.
10. Typical values, peak-to-peak noise equals 6 times rms noise.
11. Based on settled signal: 100μs pulse trigger delay.
12. Also applies to other apertures that are integer multiples of 1PLC.
13. Recovery to within 20mV of previous level.

Model 2306-VS Specifications

SPECIALIZED POWER SUPPLIES

1.888.KEITHLEY (U.S. only)

www.keithley.com

KEITHLEY

A GREATER MEASURE OF CONFIDENCE